

CP0016V-ASTM / CP0016VCS-ASTM

General Description

- Surface-mounted baby changing stations made of bacterial-resistant polypropylene (CP0016V-ASTM and CP0016VCS-ASTM) and with stainless steel AISI 304 exterior (only CP0016VCS-ASTM).
- High level of safety and cleanliness.
- Models offer great strength and durability, suitable for high traffic facilities.
- Trendy and stylish design.
- Biocote[®] antimicrobial additive into its own surface.
- Includes a pair of bag hooks to keep personal belongings close and at hand.
- Fully comply with the American standard ASTM F2285-04 and the European EN 12221-1 and EN 12221-2 standards.

Components & Materials

- **CP0016V:** surface-mounted baby changing station made of polypropylene in white finish.
- **CP0016VCS:** surface-mounted baby changing station made of polypropylene and with a stainless steel AISI 304 exterior, in satin finish.
- **BED:** with approximately 295 in² contoured changing surface area is made of polypropylene in white finish Biocote[®] antimicrobial additive embedded into its surface, promoting easy cleaning and reducing the growth of odor-causing and staining microbes.
- **LINER DISPENSER:** is made of polypropylene and holds approximately 80 bed liners, minimizing operator refills and discouraging potential vandalism.
- **OPEN/CLOSE MECHANISM:** concealed from the user's view, it consists of a pair of reinforced hinges and a pneumatic cylinder, ensuring high durability and a smooth opening and closing of the baby changing station.
- **MOUNTING CHASSIS:** made of steel with a cathoporesis treatment. The corresponding mounting hardware is supplied, making the unit installation to the wall easy.
- **FRONTAL CHASSIS:** (only CP0016VCS) made of one-piece AISI stainless steel, 1/32" thick, fixed to the bottom of the bed by means of 4 bolts and 4 nuts, always concealed from the user's view and without joints or edges to ensure the user's safety. This unit makes for a cleaner, seamless visual fusion with other satin finish accessories in the washroom.

Technical Specifications

Dimensions	L:21 5/8" x W:4" (closed) / 35" (open) x H:18 7/8"
Weight (empty)	29.5 Lbs. (CP0016V) 36.6 Lbs. (CP0016VCS)
Liner dispenser capacity	80 units
Recommended installation height	31 1/2" at lowest point
Recommended installation height (handicapped)	27 1/2" at lowest point

Operation

Open the BabyMedi[®] baby changing station. Place the baby on the center of the bed and change your baby's diapers. Close the BabyMedi[®] station.

Under no circumstance should the baby be left unattended at any time on top of the baby changing station in order to avoid injury from falling or slipping.

Please mark the selected item



code
CP0016V-ASTM
material
polypropylene
finish
white



code
CP0016VCS-ASTM
material
polypropylene /
stainless steel
finish
white / satin



Saniflow Corp reserves the right to make changes and/or modifications to the products and their specifications without warning or notice.

Installation

According to the installation and safety instructions manual supplied with the unit.

IMPORTANT: in order to ensure BabyMedi is properly installed it is recommended that a qualified person carries out the installation of the unit. The unit must be properly installed on a wall that is able to sustain a considerable weight and can accommodate the supplied installation hardware.

Certificates & Qualifications

Unit shall be ASTM approved, according F2285-04 standard and GS according EN 12221-1 and EN 12221-2 standards.

Ideal location

Public spaces such as, shopping centers, airports, public buildings, childcare centers, etc. Models are suitable for high traffic facilities where great strength and durability is needed.

IMPORTANT: the Congress of the United has taken a further step towards gender equality by implementing law 114-235 (10/07/2016). By this law, the American Government states that restrooms, both for men and women, in public buildings all around the country, must have diaper changing facilities in place.

Guide specification

Surface-mounted baby changing stations made of bacterial-resistant polypropylene (CP0016V and CP0016VCS) and with stainless steel AISI 304 exterior (only CP0016VCS).

BabyMedi® changing stations offer a very high level of safety and cleanliness being the ideal solution for public spaces such as, shopping centers, airports, public buildings, childcare centers, etc. Models suitable for high traffic facilities with high strength and durability.

Their trendy and stylish design, allow these baby changing stations to blend into any space perfectly.

Biocote® antimicrobial additive, based on ion silver technology, is embedded into the surface, promoting an easy cleaning and reducing the growth of odor causing and staining microbes.

BabyMedi® baby changing stations are supplied with child protection straps made of nylon assembled.

A pair of bag hooks (one at the right side and the other one at the left) help to keep personal belongings close and at hand.

BabyMedi® units fully compliant with the American standard ASTM F2285-04 and the European EN 12221-1 and EN 12221-2 standards that require baby changing stations be able to support a 110 lb static load test during one hour. Moreover, units tested in our own laboratories have withstood loads over 220 lb.

Overall dimensions:

L: 21 5/8" x W: 4" (closed) / 35" (open) x H: 18 7/8"

Weight: 29.5 Lbs. (CP0016V) / 36.6 Lbs. (CP0016VCS)

Recommended heights from floor

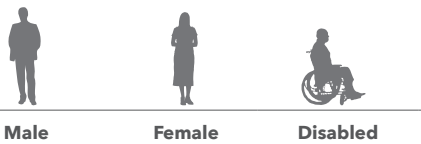

	Male	Female	Disabled
x To bottom of unit	31 1/2" (800 mm)	31 1/2" (800 mm)	27 1/2" (700 mm)
y To mounting brackets	16 3/8" (415 mm)	16 3/8" (415 mm)	12 13/32" (315 mm)

MOUNTING

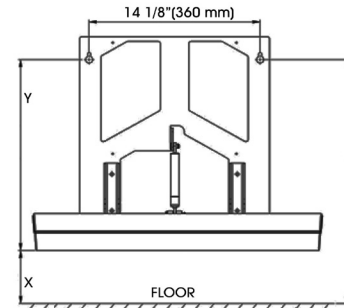

CP0016V-ASTM / CP0016VCS-ASTM

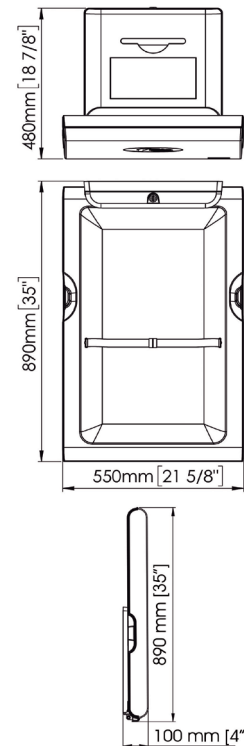

Job:

Architect / Engineer:

City / State / Country:

Model number:

Contractor:

Date:

Variations:

Customer / Wholesaler:

Quantity:

Saniflow Corp reserves the right to make changes and/or modifications to the products and their specifications without warning or notice.

For further info please contact SANIFLOW on: Toll free: **1-877-222-9125** or visit our website at **www.saniflowcorp.com**
Tel: +1 (305) 424 2433 Fax: +1 (305) 424 2435 · sales@saniflowcorp.com